

Physics 105 Class 7
APPLICATIONS OF NEWTON'S LAWS:
FRICTION

For the same magnitude of F , is one easier to get moving?

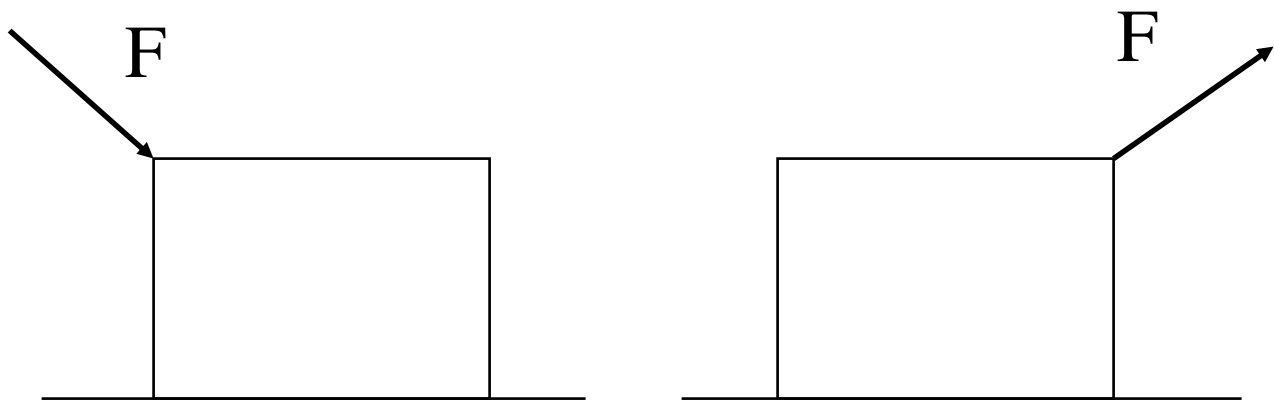

Static Friction:

Kinetic friction:

Kinetic vs. Static Friction:

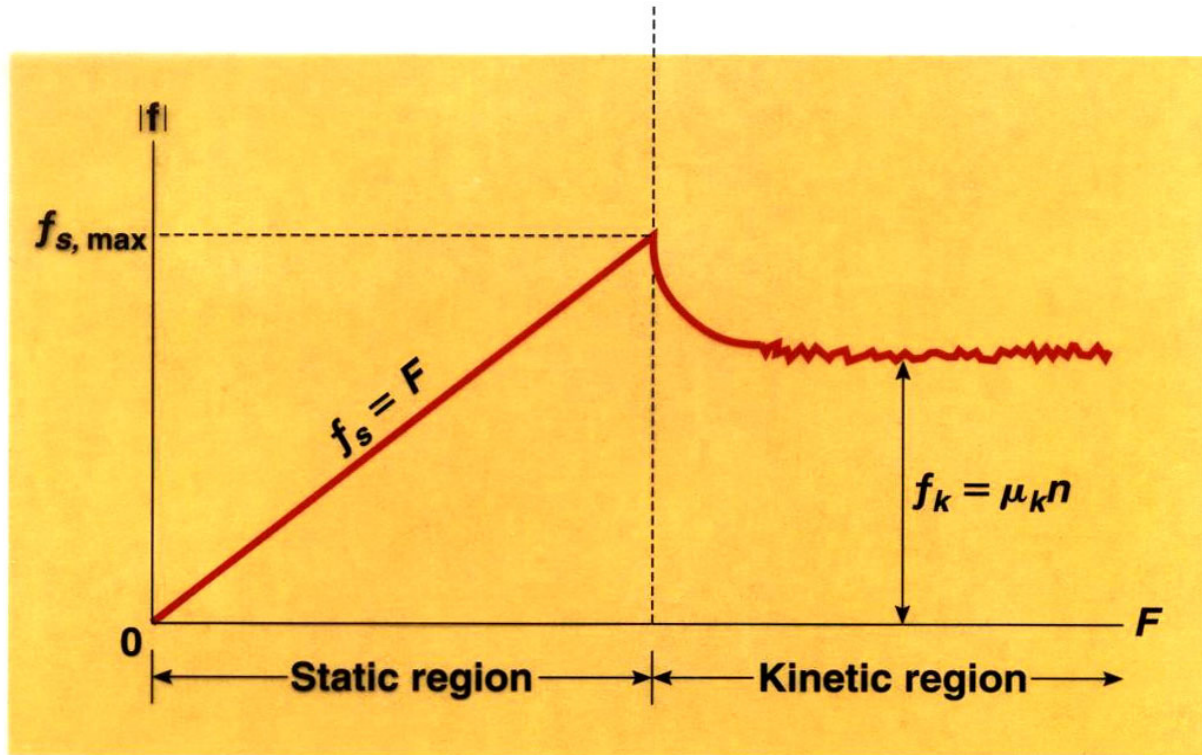

(c)

Compare the forces in breaking a rope tied to a wall

Tension vs pull force:

Tension T

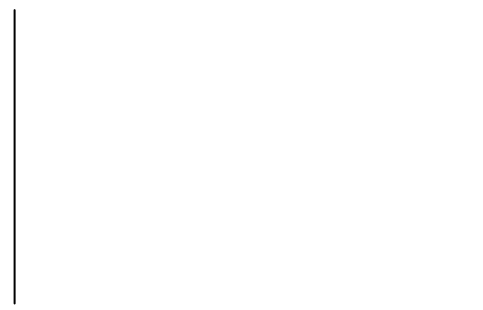

Pull P

Physics 105 Class 7

Typical coefficients of friction

	μ_s (static)	μ_k (kinetic)
Rubber on concrete	1	.8
steel on steel	0.7	0.6
metal-metal (oiled)	0.1-0.2	0.05-0.1
ice on ice	0.1	0.03
teflon on teflon	0.04	0.04
human joints	0.01	0.003

Mary pulls a box of books with mass 25 kg to the right with a rope.

$$\mu_s = 0.5 \quad \mu_k = 0.3$$

a) First she pulls horizontally on the box with a force of 40 N. The box doesn't move. What is the frictional force of the floor on the box?



Physics 105 Class 7

b) What minimum force will she have to exert to get it moving?

c) If she pulls with force 180 N, what will the acceleration be? (use kinetic friction f_k)

Physics 105 Class 7

If Mary instead pulls the 25 kg box with force 180 N at an angle of 60° above the horizontal, what will the acceleration be?

FBD:



Find the x and y components of her pull P

Find the normal force and frictional force f

Find the acceleration of the box.

Physics 105 Class 7

A 5000 kg truck has four tires with

$\mu_s = 0.75$, $\mu_k = 0.6$ (tire to road friction)

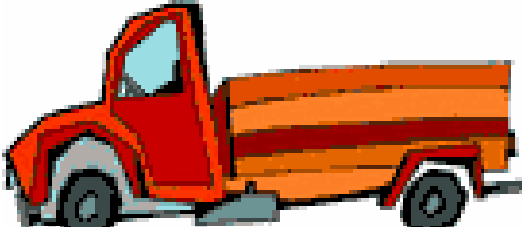

What is the *maximum acceleration* the truck can have from the tire-road friction force?

What is the maximum stopping *deceleration*?

Physics 105 Class 7

In the back of the open truck is a large box of mass 300 kg with $\mu_s = 0.4$, $\mu_k = 0.3$

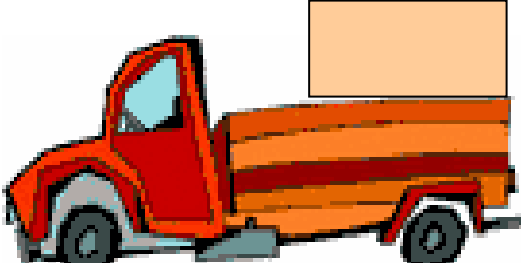

What is maximum acceleration the driver can give the truck if the box is not to slide out?

Physics 105 Class 7

Friction on slopes (inclined planes)

For the same skis and snow, as I increase the slope the ski-snow **frictional force**

- a) increases
- b) stays the same
- c) decreases

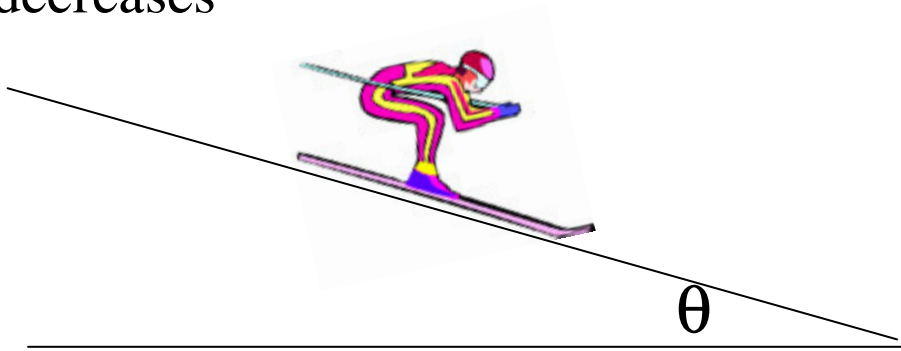

If the kinetic coefficient of friction is μ_K , find the frictional force f .

Physics 105 Class 7

You invent a new olympic sport called pulley ski jumping. If the kinetic coefficient of friction is μ , what is the acceleration? (**Like 7-1 and 7-4**)

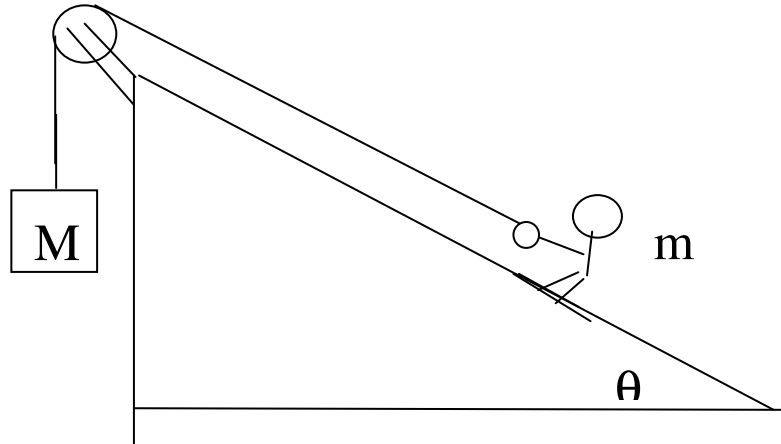

P7. If you can choose any M , what is the **greatest** acceleration you can give the skier?

Physics 105 Class 7

HOMEWORK HINTS: